

## 2A TRIACs

### Features

- Glass passivated chip junction
- High voltage and surge capability
- Low thermal resistance and durability
- Triggering in four quadrants
- Pb-free
- RoHS compliant
- SMD device halogen free

### Applications

- Static relays
- Heating regulation
- Induction motor starting circuits
- Phase control operation in light dimmers
- Motor speed controllers

### Main Features

Symbol	Value	Unit
$I_{T(RMS)}$	2	A
$V_{DRM} / V_{RRM}$	600 / 800	V

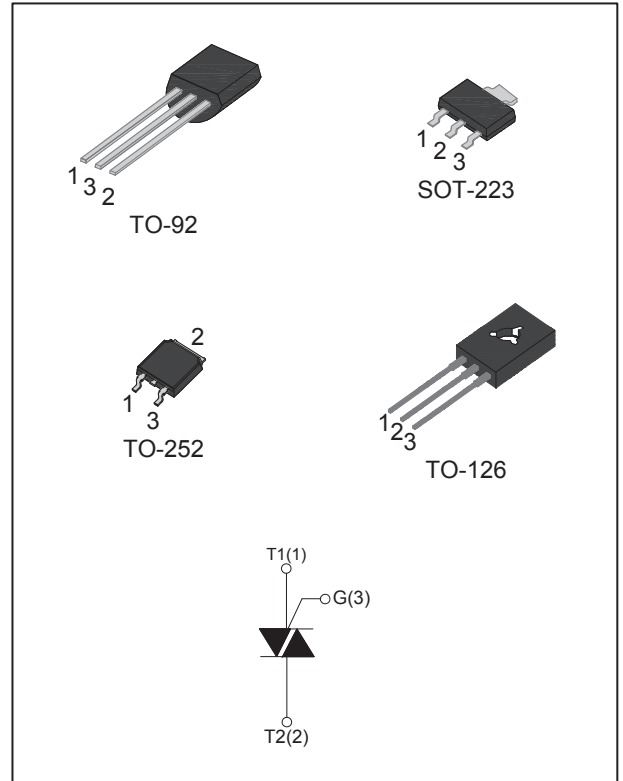

### Absolute Maximum Ratings

Parameter	Symbol	Value	Unit
Storage junction temperature range	$T_{STG}$	-40 to 150	°C
Operating junction temperature range	$T_J$	-40 to 125	°C
Repetitive peak off-state voltage ( $T_J = 25^\circ\text{C}$ )	$V_{DRM}$	600 / 800	V
Repetitive peak reverse voltage ( $T_J = 25^\circ\text{C}$ )	$V_{RRM}$	600 / 800	V
RMS on-state current	TO-92 ( $T_C=90^\circ\text{C}$ )	2	A
	SOT-223 ( $T_C=103^\circ\text{C}$ )		
	TO-252 ( $T_C=103^\circ\text{C}$ )		
	TO-126 ( $T_C=103^\circ\text{C}$ )		
Non repetitive surge peak on-state current ( $180^\circ$ conduction angle, $F = 50\text{Hz}$ , $t_P = 20\text{ms}$ , full cycle)	$I_{TSM}$	20	A
$I^2t$ value for fusing ( $t_P = 10\text{ms}$ )	$I^2t$	2	$\text{A}^2\text{s}$
Critical rate of rise of on-state current ( $I_G = 2 \times I_{GT}$ , $t_r \leq 100\text{ns}$ )	$dI/dt$	50	$\text{A}/\mu\text{s}$
Peak gate current	$I_{GM}$	2	A
Average gate power dissipation	$P_{G(AV)}$	1	W

## Electrical Characteristics ( $T_J = 25^\circ\text{C}$ unless otherwise specified)

Standard (4 Quadrants)

Symbol	Test Condition	Quadrant		Value		Unit
$I_{GT}$	$V_D = 12\text{V}, R_L = 100\Omega$	I - II - III	MAX	5	10	mA
		IV		10	25	
$V_{GT}$	$V_D = 12\text{V}, R_L = 100\Omega$	ALL	MAX	1.3		V
$V_{GD}$	$V_D = V_{DRM}, T_J = 125^\circ\text{C}$	ALL	MIN	0.2		V
$I_L$	$I_G = 1.2 \times I_{GT}$	I - III	MAX	5	20	mA
		II - IV		10	35	
$I_H$	$V_{AK} = 12\text{V}, I_{GK} = 100\text{mA}$		MAX	5	20	mA
dV/dt	$V_D = 67\% V_{DRM}, \text{Gate open}, T_J = 125^\circ\text{C}$		MIN	15	100	V/ $\mu\text{s}$

## Static Characteristics

Symbol	Test Condition			Value	Unit
$V_{TM}$	$I_{TM} = 2.8\text{A}, t_P = 380\mu\text{s}$	$T_J = 25^\circ\text{C}$	MAX	1.55	V
$I_{DRM}$ $I_{RRM}$	$V_D = V_{DRM}, V_R = V_{RRM}$	$T_J = 25^\circ\text{C}$	MAX	10	$\mu\text{A}$
		$T_J = 125^\circ\text{C}$		1	mA

## Thermal Resistances

Symbol	Parameter		Value	Unit
$R_{\theta JC}$	Junction to case(AC)	TO-92	20	$^\circ\text{C/W}$
		SOT-223	5.8	
		TO-252	4.5	
		TO-126	4.5	

## Ordering Information

Ordering Type	Marking	Package	Quantity	Delivery Mode
BT02xx-yyA	BT02xx-yyA	TO-92	1,000	Bag
BT02xx-600N	B02xx-6	SOT-223	4,000	13" diameter reel
BT02xx-800N	B02xx-8	SOT-223	4,000	13" diameter reel
BT02xx-yyDP	BT02xx-yyDP	TO-252	3,000	13" diameter reel
BT02xx-600D	B02xx-6	TO-126	50	Tube
BT02xx-800D	B02xx-8	TO-126	50	Tube

Note : xx = sensitivity, yy = voltage

## Ordering Information Scheme

**BT 02 10 - 600 A**

**Triac series**

BT = 4 Quadrants

**$I_{T(RMS)}$**

02 = 2A

**$I_{GT}$  Sensitivity**

10 = 5/5/5/10mA

25 = 10/10/10/25mA

**$V_{DRM}$  /  $V_{RRM}$**

600 = 600V

800 = 800V

**Package type**

A = TO-92

N = SOT-223

DP = TO-252

D = TO-126

## Ratings and Characteristics Curves

Fig.1 - RMS on-state current versus case temperature

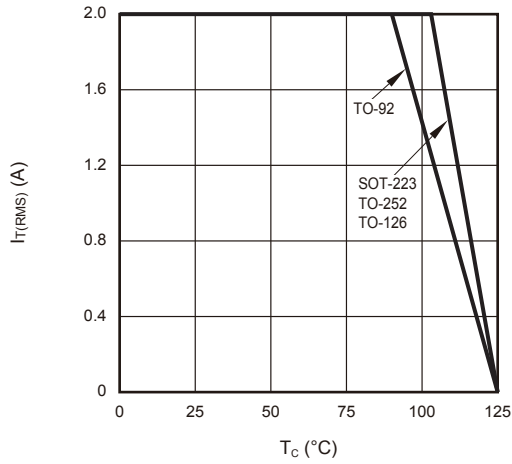

Fig.2 - Surge peak on-state current versus number of cycles

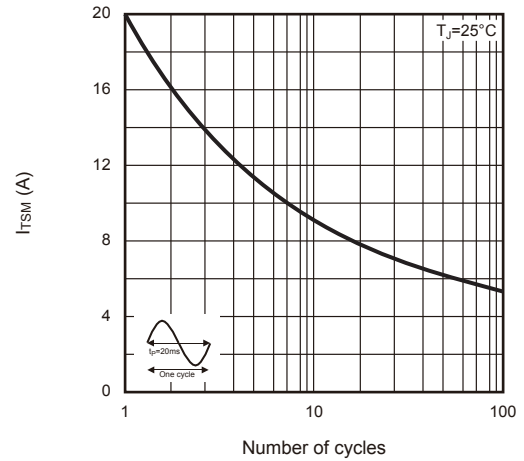

Fig.3 - On-state characteristics (maximum values)

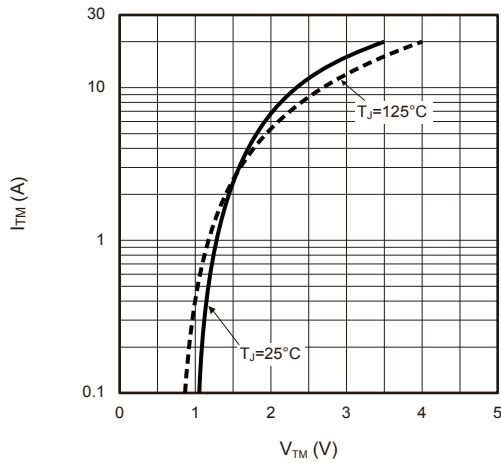

Fig.4 - Maximum power dissipation versus RMS on-state current

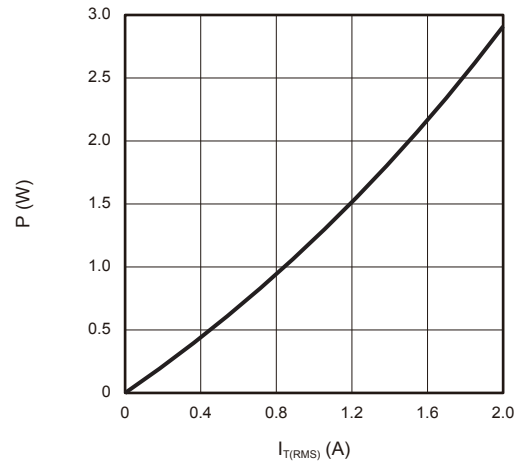

Fig.5 - Relative variations of gate trigger current versus junction temperature

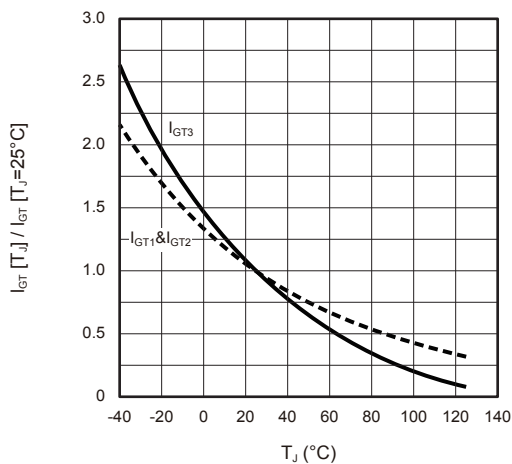
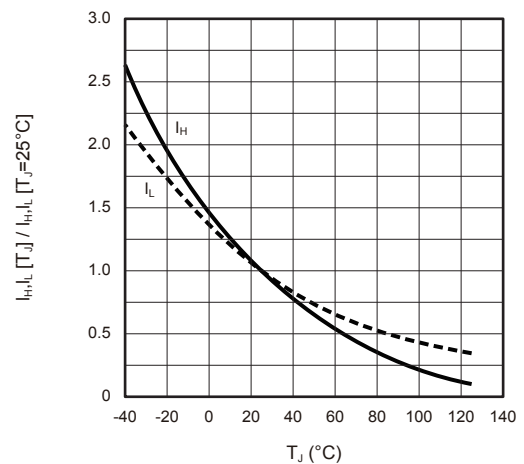
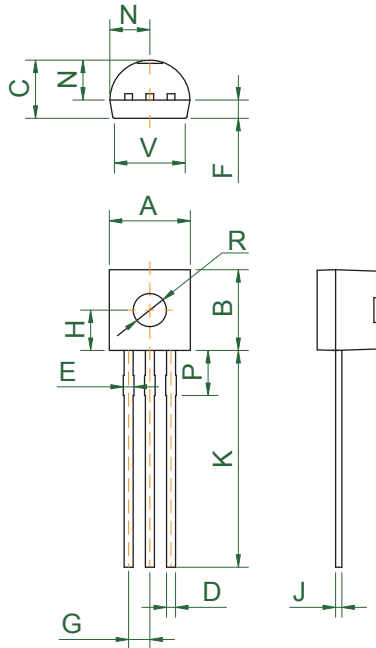

Fig.6 - Relative variations of holding current, latching current versus junction temperature



## Package Outline Dimensions

### TO-92



Ref.	Dimensions					
	Millimeters			Inches		
	Min.	Typ.	Max.	Min.	Typ.	Max.
A	4.3	-	5.2	.169	-	.205
B	4.3	-	5.33	.169	-	.210
C	3.18	-	4.19	.125	-	.165
D	0.254	-	0.55	.010	-	.022
E	0.3	-	0.8	.012	-	.032
F	1.0	-	1.4	.039	-	.055
G	1.14	-	1.4	.045	-	.055
H	-	2.3	-	-	.091	-
J	0.3	-	0.51	.012	-	.020
K	12.7	-	15.0	.500	-	.591
N	2.04	-	2.66	.080	-	.105
P	1.86	-	2.06	.073	-	.081
R	-	-	1.5	-	-	.059
V	3.43	-	4.5	.135	-	.177

### SOT-223

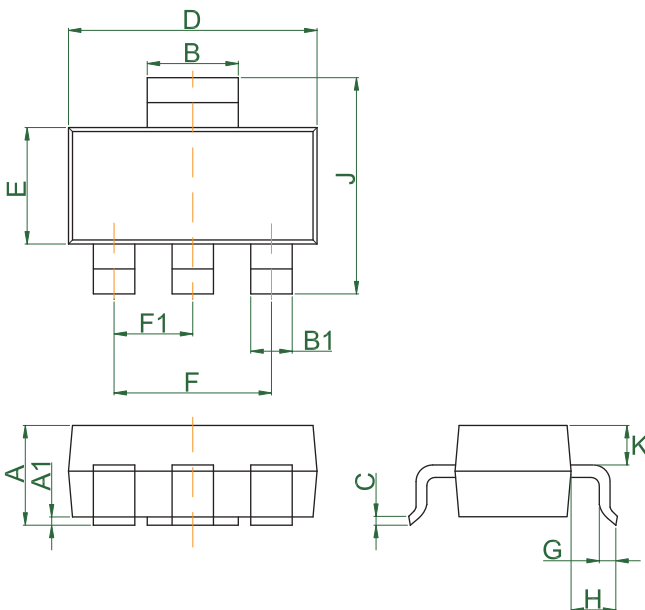

Ref.	Dimensions					
	Millimeters			Inches		
	Min.	Typ.	Max.	Min.	Typ.	Max.
A	1.5	-	1.8	.059	-	.071
A1	0	-	0.12	.000	-	.005
B	2.9	-	3.1	.114	-	.122
B1	0.6	-	0.8	.024	-	.032
C	0.22	-	0.32	.009	-	.013
D	6.2	-	6.7	.244	-	.264
E	3.3	-	3.7	.130	-	.146
F	-	4.6	-	-	.181	-
F1	-	2.3	-	-	.091	-
G	0.7	-	1.1	.028	-	.043
H	1.5	-	2.0	.059	-	.079
J	6.7	-	7.3	.264	-	.287
K	0.8	-	1.0	.031	-	.039

## Package Outline Dimensions

**TO-252**

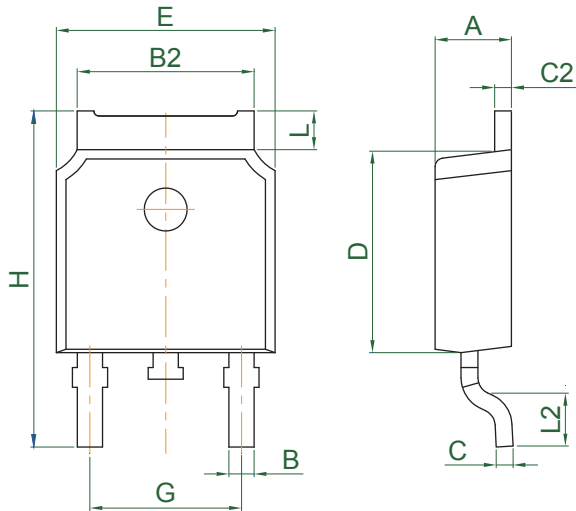

Ref.	Dimensions					
	Millimeters			Inches		
	Min.	Typ.	Max.	Min.	Typ.	Max.
A	2.1	-	2.5	.083	-	.098
B	0.55	-	0.96	.022	-	.038
B2	4.98	-	5.58	.196	-	.220
C	0.4	-	0.62	.016	-	.024
C2	0.37	-	0.99	.015	-	.039
D	5.8	-	6.4	.228	-	.252
E	6.3	-	6.9	.248	-	.272
G	4.4	-	4.7	.173	-	.185
H	9.35	-	10.7	.368	-	.421
L	1.09	-	1.5	.043	-	.059
L2	1.35	-	2.2	.053	-	.087

**TO-126**

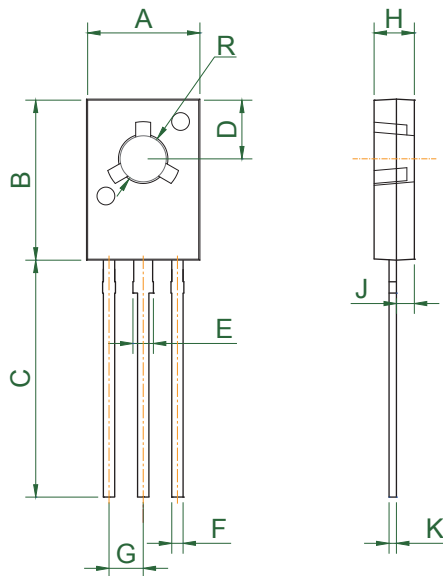

Ref.	Dimensions					
	Millimeters			Inches		
	Min.	Typ.	Max.	Min.	Typ.	Max.
A	7.4	-	8.15	.291	-	.321
B	10.6	-	11.2	.417	-	.441
C	15.3	-	16.3	.602	-	.642
D	3.6	-	4.1	.142	-	.161
E	1.17	-	1.47	.046	-	.058
F	0.66	-	0.86	.026	-	.034
G	2.15	-	2.45	.085	-	.097
H	2.5	-	2.9	.098	-	.114
J	1.1	-	1.5	.043	-	.059
K	0.45	-	0.6	.018	-	.024
R	3.0	-	3.5	.118	-	.138